



The National Institute for Innovation in Manufacturing Biopharmaceuticals

Process Automation System (PAS) Control Narrative

VERSION 1
May 31, 2023



Revision History

Revision Number	Date	Description of Changes
1	May 31, 2023	Original Version



Table of Contents

- 1 Acronyms and Definitions 4
- 2 Process Control Requirements..... 4
 - 2.1 Overview 4
 - 2.2 Surge Vessel..... 5
 - 2.2.1 Addition Control:..... 6
 - 2.2.2 Divert Valve..... 6
 - 2.2.3 Alarm 7
 - 2.3 Process Configuration 7
 - 2.4 Cell Culture and Production 7
 - 2.4.1 Bioreactor 7
 - 2.4.2 Perfusion..... 7
 - 2.4.3 Alarms 7
 - 2.5 Harvest/Capture..... 7
 - 2.5.1 Polishing Chromatography #1 7
 - 2.5.2 Polishing Chromatography #2 12
 - 2.5.3 Depth Filtration 17
 - 2.5.4 Viral Inactivation 25
 - 2.6 Purification/Polishing Chromatography 32
 - 2.6.1 Single Use Chromatography: 32
 - 2.6.2 Viral Filtration: 32
 - 2.7 Filtration (Post Viral / Formulation) 33
 - 2.7.1 ILDF/UFD 33
 - 2.8 Equipment Interfaces 40

1 Acronyms and Definitions

Abbreviation	Definition
AIT	Analogue Indicating Transmitter
AT	Analogue Transmitter
ATF	Alternating Tangential Filtration
BOD	Basis Of Design
EM	Equipment Module
FIT	Flow Indicating Transmitter
FT	Flow Transmitter
ILDF	In-Line Depth Filtration
IO	Input-Output
MC	Motor Contactor
N/A	Not Applicable
NIIMBL	National Institute for Innovation in Manufacturing Biopharmaceuticals Lab
OEM	Original Equipment Manufacturer
OOS	Out Of Specification
OPC UA	Open Platform Communications Unified Architecture
PAS	Process Automation System
PCC	Periodic Counter-current Chromatography
P&ID	Piping & Instrumentation Diagram
PLC	Programmable Logic Controller
PV	Process Variable
RPM	Revolutions Per Minute
SP	Setpoint
SPTFF	Single Pass Tangential Flow Filtration
SUSV	Single Use Surge Vessel
UF/DF	Ultra Filtration / Depth Filtration
UV	Ultraviolet
VI	Viral Inactivation
VRF	Viral Removal Filtration
WIT	Weight Indicating Transmitter

2 Process Control Requirements

2.1 Overview

For the Basis of Design (BoD), there are four different processes.

- Fed Batch
- Intensified Fed Batch
- Hybrid Perfusion Process
- Continuous Perfusion Process

The new manufacturing plant is to be capable to operate each of the above processes. The following sections summarize the process control for each process steps to manufacture bulk drug substance.

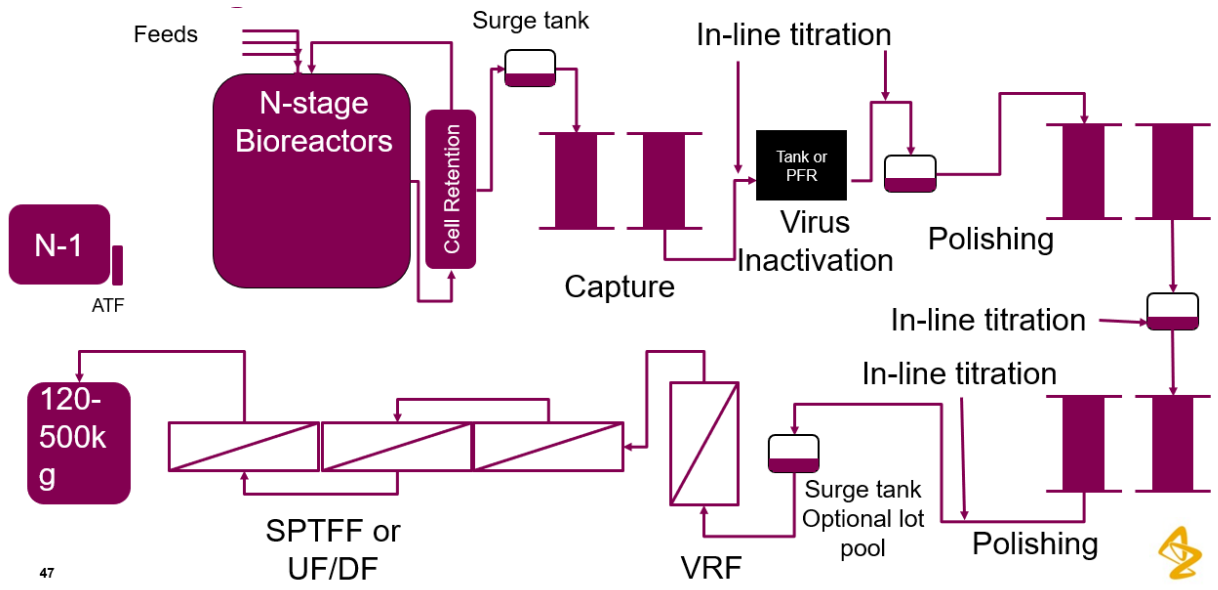

Figure 1 – Common Framework for Integrated and Continuous Processing.

For some unit operations, the PAS system will communicate with skid-mounted OEM control supplied by the skid vendor. The communication interfaces are defined in section 2.8. The PAS will treat these systems as black boxes, sending and receiving predefined communications.

2.2 Surge Vessel

The test bed will have the following surge vessels. The equipment and automation for each will be identical.

Vessel	Description
SV01	ProA Surge Vessel
SV02	Viral Inactivation Surge Vessel
SV03	Depth Filtration Surge Vessel
SV04	Polishing 1 Surge Vessel
SV05	Polishing 2 Surge Vessel
SV06	Viral Filtration Surge Vessel
SV07	UltraFiltration Surge Vessel

2.2.1 Addition Control:

The addition control equipment module class is used to control vessel pH or conductivity. The setpoints for the equipment module are Hold, Shutdown, and Addition Polynomial Control.

In the Hold setpoint, vessel weight monitoring and addition control is disabled.

In the Shutdown setpoint, vessel weight monitoring and addition control is disabled.

In the Addition Polynomial Control setpoint, vessel weight monitoring is enabled. When vessel weight is above the minimum vessel weight, the vessel weight monitoring logic will enable the Addition Control logic. If the vessel weight is above high weight limit, then Addition control logic is disabled. The Addition Control logic works as follows:

If Hi side addition is enabled and the measured pH/conductivity is below the setpoint (by an amount greater than a configurable deadband) or Lo side addition is enabled and the measured pH/conductivity is above the setpoint (by an amount greater than a configurable deadband), and the system is not waiting a post-addition mixing time, then the Addition Control logic will add solution for a calculated length of time. For pH control, base will be used for Hi Side control and acid will be used for Lo Side control. The addition time is calculated by the polynomial equation below but cannot exceed a configurable maximum limit for Lo side and Hi side addition, respectively.

$$\text{Addition Time} = [C1 \times (SP - PV)^2] + [C2 \times |(SP - PV)|] + C3$$

where SP is the pH/conductivity control setpoint, PV is the measured pH/conductivity process value, and C1, C2, and C3 are constants. The values of C1, C2, and C3 are unique for Lo side and Hi side additions and are dependent on whether the PV is above or below a configurable Lo side pH/conductivity break point or Hi side pH/conductivity break point.

After an addition is complete, the Addition Control logic waits for a configured mixing time before allowing another addition to occur.

The EM shall allow flexibility to perform control and ability to select one of the two pumps for each sided control.

An alarm is triggered in each SUSV during Feed if the incoming flow rate into the SUSV minus Outgoing flow rate minus the SUSV rate of weight change is not zero within a configurable tolerance for a configurable time.

2.2.2 Divert Valve

The divert valve is used to divert flow if the skid feed SUSV weight is high or operator overrides manually.

Divert Valve will be assigned to the SUSV. The valve logic will monitor feed SUSV weight assigned to the skid to divert the flow. Operator can manually override the flow path using the skid EM operating parameter to which the SUSV is actively connected. When the weight control functionality is disabled, the divert valves are placed in a hold state.

2.2.3 Alarm

An alarm is triggered in each SUSV during Feed if the incoming flow rate into the SUSV minus Outgoing flow rate minus the SUSV rate of weight change is not zero within a configurable tolerance for a configurable time.

2.3 Process Configuration

The user will have the ability to reconfigure the order of the unit operations prior to the start of each run. This includes switching the sequence (e.g. capture chromatography, depth filtration, polishing chromatography 1 --> capture chromatography, polishing chromatography 1, depth filtration). A user interface using unit operating parameter will allow the user to assign surge vessel to the batch unit.

2.4 Cell Culture and Production

2.4.1 Bioreactor

The PAS will interface with the bioreactor OEM skid to collect and historize process variables.

2.4.2 Perfusion

The PAS will interface with the perfusion OEM skid to collect and historize process data.

2.4.3 Alarms

The following enhancement to the alarm strategy is included in the scope.

- Alarm's rationalization will be performed to enable and disable process alarms during the active process step.
- SUSV alarms will be enabled and disabled during the active skid process.
- Disable Module bad alarms when the skid or SUSV is disconnected.

2.5 Harvest/Capture

2.5.1 Polishing Chromatography #1

2.5.1.1 Overview

The PAS will interface with the polishing chromatography OEM skid #1 to collect and historize process data. Note that each process skid has a unique interfaces and command list.

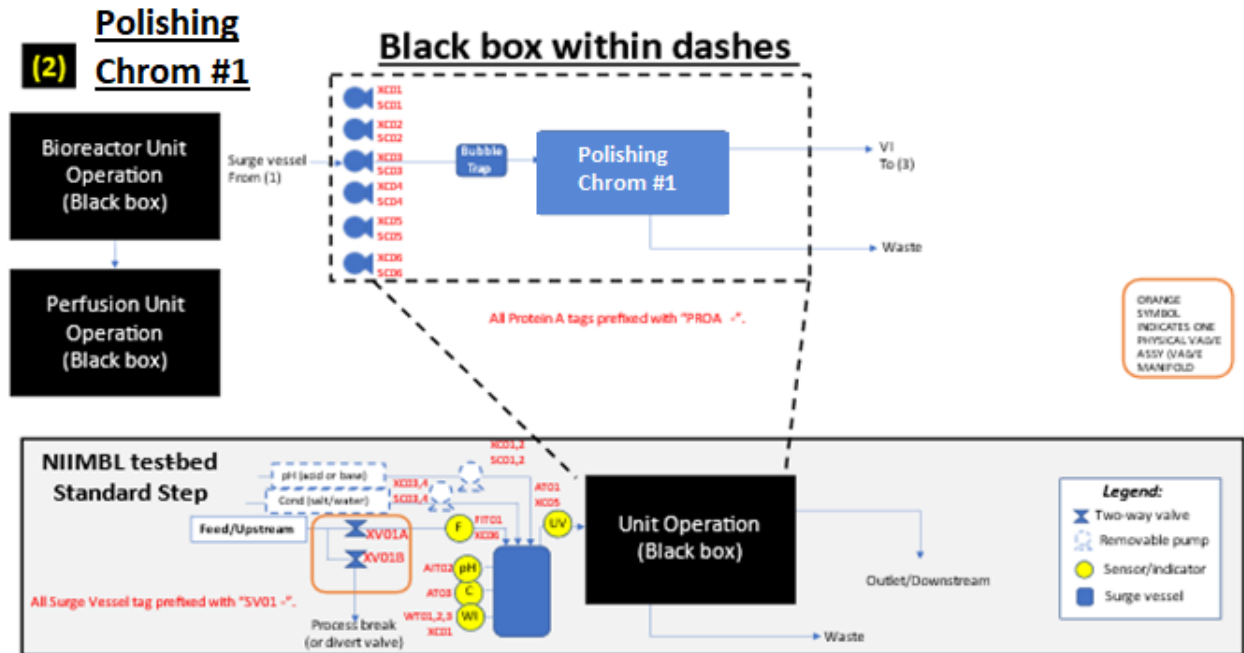

2.5.1.2 Phase

The PAS Polishing Chromatography Phase will initialize, start, and stop the recipe on the OEM skid to facilitate procedural operations based on recipe parameter values. The Phase is also responsible for monitoring the end of the running batch based on the operator acknowledgement or auto shutdown detection if the upstream skid batch goes to an idle state.

The feed SUSV and collection SUSV are assigned to the unit operation using the recipe formula.

The phase will update the unit state to Start up, Feed, Pause, Shutdown (Draw down is complete), Abort, Idle.

2.5.1.3 Equipment Module

The EM regulates the standard feed process rate on the skid using a method by monitoring the feed and collection SUSV weight assigned to the skid. The permitted feed process rate setpoints include Pause, Slow, Fast, and Normal. The EM will pause the skid if the feed SUSV pH is OOS (for 10S).

The skid master EM will transition from feed to an end setpoint by the phase upon operator acknowledgement or auto shutdown detection if the upstream skid batch goes to an idle state.

The equipment module will run following command sequences.

- Hold
- Startup
- Feed/Process

- Shutdown
- Abort

2.5.1.3.1 Startup command sequence

Wait for the assigned feed SUSV weight to be above minimum weight

If Feed SUSV pH is enabled, then

Set Feed SUSV pH EM Command to pH control

Enable Feed SUSV pH High and Low alarms

If Feed SUSV Cond is enabled, then

Set Feed SUSV Cond EM Command to Cond control

Enable Feed SUSV Cond High and Low alarms

Wait for the Feed SUSV WT to be above Normal weight limit

Enable Feed SUSV Weight High and Low Alarms

If pH or Cond is enabled, then

Wait for pH or Cond in range

2.5.1.3.2 Feed command sequence

Load and start skid recipe

Enable Skid Speed Control:

If Feed SUSV WT is less than Slow Speed Weight Limit and greater than pause weight limit or Collection SUSV WT is greater than Coll High Weight Limit, then

Set skid flow rate to the Slow Method

If Feed SUSV WT is greater than Slow Speed Weight Limit and less than High Speed Weight limit, then

Set skid flow rate to the Normal Method

If Feed SUSV WT is greater than Fast Speed Weight limit, then

Set skid flow rate to the Fast Method

If Feed SUSV WT is less than Pause Weight Limit or Feed SUSV pH or Cond is enabled and Feed SUSV pH or Cond is out of range or Collection SUSV WT is greater than Coll High High Weight Limit, then

Pause skid recipe

Enable Divert Valve Control:

If Feed SUSV weight is greater than High Weight Limit

open process break valve

close outlet valve

Else

open outlet valve

close process break valve

Start External Pumps

Six new external pumps will be added to the BioSMB skid using charms IO's. These pumps will be controlled in the PAS and allow external skid PLC control to drive the pumps flow setpoint during the local skid recipe run.

2.5.1.3.3 Shutdown command sequence

If Feed SUSV WT is greater than Slow Speed Weight Limit and less than High Speed Weight limit, then

Set skid flow rate to the Normal Method

If Feed SUSV WT is greater than Fast Speed Weight limit, then

Set skid flow rate to the Fast Method

If Feed SUSV WT is less than Pause Weight Limit or Feed SUSV pH or Cond is enabled and Feed SUSV pH or Cond is out of range or Collection SUSV WT is greater than Coll High High Weight Limit, then

Pause skid recipe

Wait for the Feed SUSV weight to be below empty weight limit

Disable Feed Pump Speed Control

Stop Feed Pump

Stop External Pumps

2.5.1.3.4 Abort command sequence

Disable Feed Pump Speed Control

Disable Divert Valve Control

If Feed SUSV pH is enabled, then

Set Feed SUSV pH EM Command to Shutdown

Disable Feed SUSV pH High and Low alarm

If Feed SUSV Cond is enabled, then

Set Feed SUSV Cond EM Command to Shutdown

Disable Feed SUSV Cond High and Low alarm

Disable Feed SUSV Weight High and Low Alarm

Shutdown the skid

Close all valves

Stop six external pumps MC01- MC06

2.5.1.3.5 Hold command sequence

Disable Feed Pump Speed Control

Pause the skid

Stop All 6 External Pumps

2.5.1.3.6 Failure Monitor

Skid paused locally

2.5.1.4 Alarms

List of unit alarms:

Feed SUSV AIT02 High Alarm

Feed SUSV AIT02 Low Alarm

Feed SUSV AT03 High Alarm

Feed SUSV AT03 Low Alarm

Feed SUSV WT01 High Alarm

Feed SUSV WT01 Low Alarm

- Alarm's rationalization will be performed to enable and disable process alarms during the active process step.
- SUSV alarms will be enabled and disabled during the active skid process.
- Disable Module bad alarms when the skid or SUSV is disconnected.

2.5.1.5 Interlocks

Interlock Condition	Device	Safe State
---------------------	--------	------------

N/A	N/A	N/A
-----	-----	-----

2.5.2 Polishing Chromatography #2

2.5.2.1 Overview

The PAS will interface with the polishing chromatography OEM skid #1 to collect and historize process data. Note that each process skid has a unique interfaces and command list.

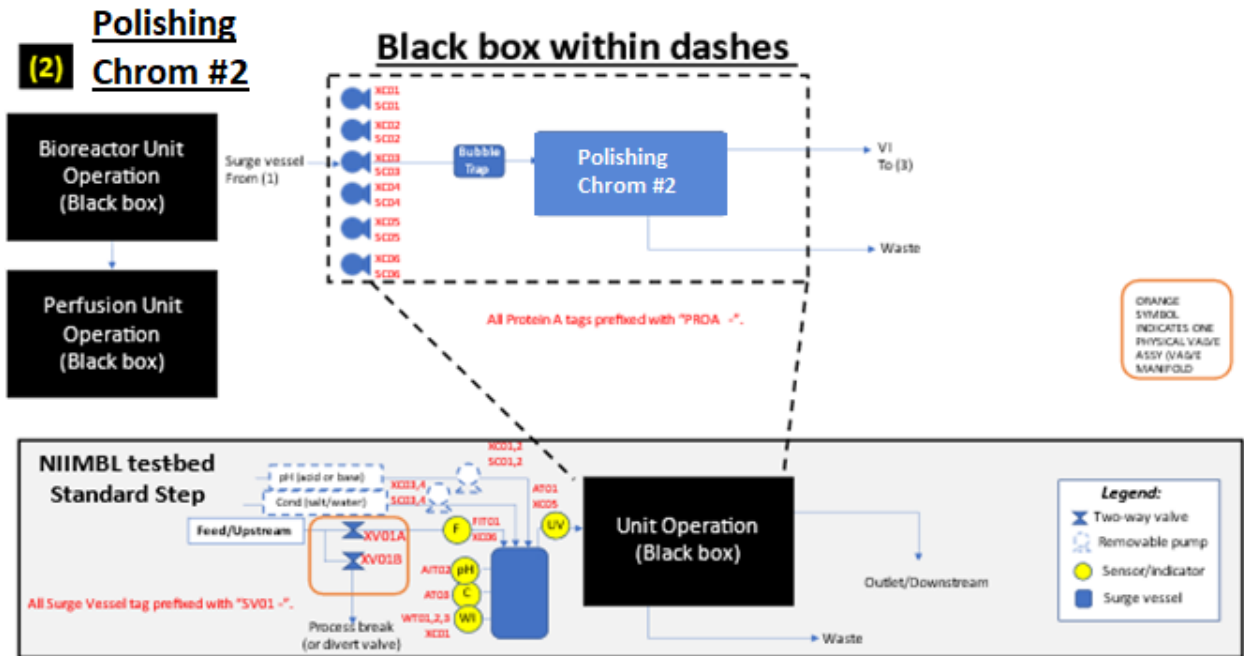

2.5.2.2 Phase

The chromatography Skid Control Phases will initialize, start, and stop the recipe on the OEM skid to facilitate procedural operations based on recipe parameter values. The Phase is also responsible for monitoring end of the running batch based on the operator acknowledgement or auto shutdown detection if the upstream skid batch goes to an idle state (N/A for ProA skid).

Feed SUSV and collection SUSV are assigned to the unit operation using the recipe formula.

The Phases will update the unit state to Start up, Feed, Pause, Shutdown (Draw down is complete), Abort, Idle

2.5.2.3 Equipment Module

The EM regulates the standard feed process rate on the skid using a flow setpoint by monitoring the feed and collection SUSV weight assigned to the skid. The permitted feed process rate setpoints include Pause, Slow, Fast, and Normal. The EM will pause the skid if the feed SUSV pH is OOS (for 10S).

The skid master EM will transition from feed to an end setpoint by the phase upon operator acknowledgement or auto shutdown detection if the upstream skid batch goes to an idle state.

The equipment module will run following command sequences.

- Hold
- Startup
- Feed/Process
- Shutdown
- Abort

2.5.2.3.1 Startup command sequence

Wait for the assigned feed SUSV weight to be above minimum weight

If Feed SUSV pH is enabled, then

Set Feed SUSV pH EM Command to pH control

Enable Feed SUSV pH High and Low alarm

If Feed SUSV Cond is enabled, then

Set Feed SUSV Cond EM Command to Cond control

Enable Feed SUSV Cond High and Low alarm

Wait for the Feed SUSV WT to be above Normal weight limit

Enable Feed SUSV Weight High and Low Alarm

If pH or Cond is enabled, then

Wait for pH or Cond in range

2.5.2.3.2 Feed command sequence

Load and start skid recipe

Enable Skid Speed Control:

If Feed SUSV WT is less than Slow Speed Weight Limit and greater than pause weight limit or Collection SUSV WT is greater than Coll High Weight Limit, then

Set skid flow rate to Slow speed setpoint

If Feed SUSV WT is greater than Slow Speed Weight Limit and less than High Speed Weight limit, then

If Control Type is Discrete, then

Set skid flow rate to Normal speed setpoint

If Control Type is Proportional, then

Set Skid flow rate to Feed SUSV Weight Control Setpoint

If Feed SUSV WT is greater than Fast Speed Weight limit, then

Set skid flow rate to Fast speed setpoint

If Feed SUSV WT is less than Pause Weight Limit or Feed SUSV pH or Cond is enabled and Feed SUSV pH or Cond is out of range or Collection SUSV WT is greater than Coll High High Weight Limit, then

Pause skid recipe

Enable Divert Valve Control:

If Feed SUSV weight is greater than High Weight Limit

open process break valve

close outlet valve

Else

open outlet valve

close process break valve

2.5.2.3.3 Shutdown command sequence

If Feed SUSV WT is greater than Slow Speed Weight Limit and less than High Speed Weight limit, then

If Control Type is Discrete, then

Set skid flow rate to Normal speed setpoint

If Control Type is Proportional, then

Set Skid flow rate to Feed SUSV Weight Control Setpoint

If Feed SUSV WT is greater than Fast Speed Weight limit, then

Set skid flow rate to Fast speed setpoint

If Feed SUSV WT is less than Pause Weight Limit or Feed SUSV pH or Cond is enabled and Feed SUSV pH or Cond is out of range or Collection SUSV WT is greater than Coll High High Weight Limit, then

Pause skid recipe

Wait for the Feed SUSV weight to be below empty weight limit

Disable Feed Pump Speed Control

Shutdown the skid

2.5.2.3.4 Abort command sequence

Disable Feed Pump Speed Control

Disable Divert Valve Control

If Feed SUSV pH is enabled, then

Set Feed SUSV pH EM Command to Shutdown

Disable Feed SUSV pH High and Low alarm

If Feed SUSV Cond is enabled, then

Set Feed SUSV Cond EM Command to Shutdown

Disable Feed SUSV Cond High and Low alarm

Disable Feed SUSV Weight High and Low Alarm

Stop Feed Pump

2.5.2.3.5 Hold command sequence

Disable Feed Pump Speed Control

Pausing the skid

2.5.2.3.6 Failure Monitor

Skid paused locally

2.5.2.4 Alarms

List of unit alarms:

Feed SUSV AIT02 High Alarm

Feed SUSV AIT02 Low Alarm

Feed SUSV AT03 High Alarm

Feed SUSV AT03 Low Alarm

Feed SUSV WT01 High Alarm

Feed SUSV WT01 Low Alarm

- Alarm's rationalization will be performed to enable and disable process alarms during the active process step.
- SUSV alarms will be enabled and disabled during the active skid process.
- Disable Module bad alarms when the skid or SUSV is disconnected.

2.5.2.5 Interlocks

Interlock Condition	Device	Safe State
N/A	N/A	N/A

2.5.3 Depth Filtration

2.5.3.1 Overview

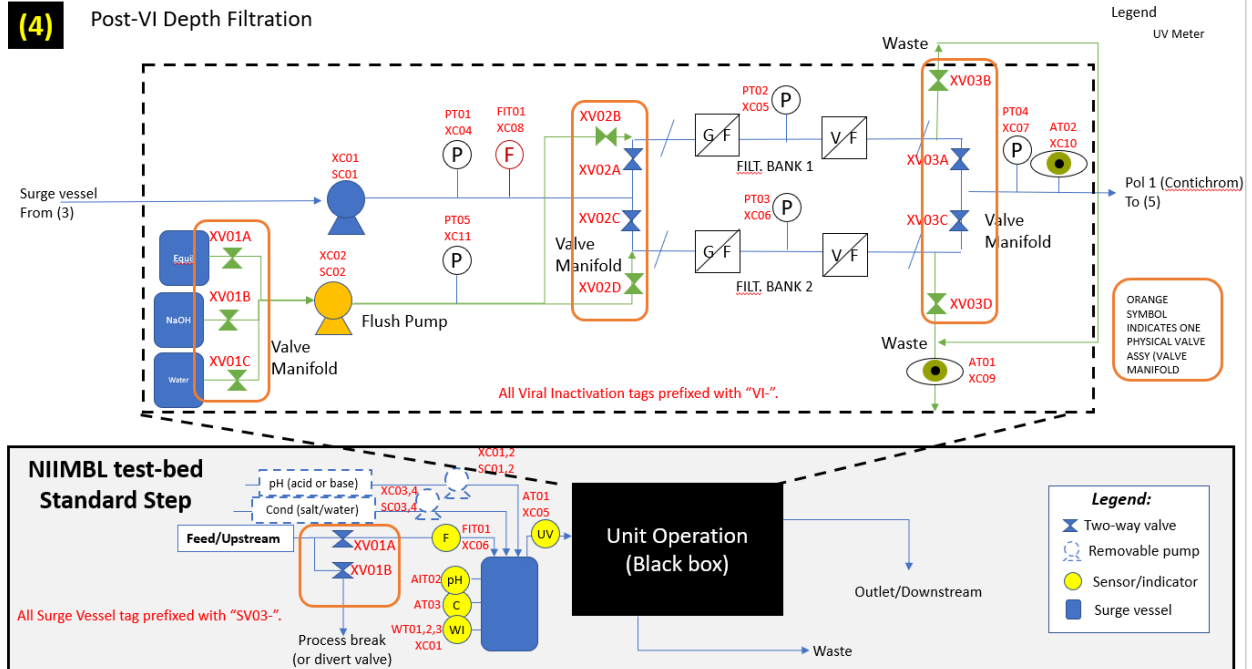

Figure – P&ID Diagram

Devices	Filter 1 Feed	Filter 2 Feed	Filter 1 Flush	Filter 2 Flush	Filter 1 Buffer Pushout	Filter 1 Product Pushout	Filter 2 Buffer Pushout	Filter 2 Product Pushout
XV02A	O	C	C	O	O	C	C	O
XV02B	C	O	O	C	C	O	O	C
XV02C	C	O	O	C	C	O	O	C
XV02D	O	C	C	O	O	C	C	O
XV03A	O	C	C	O	C	O	O	C
XV03B	C	O	O	C	O	C	C	O
XV03C	C	O	O	C	O	C	C	O
XV03D	O	C	C	O	C	O	O	C

Table – Valve Path

2.5.3.2 Phase

The Viral and Depth Skid Control Phase will initialize, start, Feed and Shutdown the equipment module to facilitate procedural operations based on recipe parameter values. The Phase is also responsible for monitoring end of the running batch based on the operator acknowledgement or auto shutdown detection if the upstream skid batch goes to an idle state. Feed SUSV and collection SUSV are assigned to the unit operation using the recipe formula. The Phase will update the unit state to Start up, Feed, Pause, Shutdown (Draw down is complete), Abort, Idle.

2.5.3.3 Equipment Module

The EM regulates the standard feed process rate on the skid using flow or speed setpoint by monitoring the feed and collection SUSV weight assigned to the skid. The permitted feed process rate setpoints include Pause, Slow, Fast, and Normal. The EM will pause the skid if the feed SUSV pH is OOS (for 10S).

The skid master EM will transition from feed to an end setpoint by the phase upon operator acknowledgement or auto shutdown detection if the upstream skid batch goes to an idle state.

The equipment module will run following command sequences.

- Startup
- Feed/Process
- Shutdown
- Abort
- Hold

2.5.3.3.1 Startup command sequence

Prompt Operator to start flush.

Tare PT01, PT02, PT03 and PT04, PT05 pressure.

Tare Feed vessel AT01, skid AT01 and AT02 UV meter.

Enable PT01 High High and High alarm.

Enable Filter Feed Differential Pressure (P01-P04) High High and High Alarm

Disable Feed vessel WT, pH, and Cond alarms.

Set active filter valve path to flush.

Start the selected filter Bank flush sequence.

Enable Filter Flush Sequence:

If Flush 1 = Inlet 1 then

Open Inlet 1 valve

Else Flush 1 = Inlet 2 then



Open Inlet 2 Valve

Else Flush 1 = Inlet 3 then

Open Inlet 3 Valve

Start Flush Pump at Flush 1 RPM Setpoint

Wait for Flush 1 Time

Stop Flush Pump

Close Inlet 1

Wait for Flush 1 Hold time.

Proceed to next flush.

Else Proceed to Flush 2

If Flush 2 = Inlet 2 then

Open Inlet 2 valve

Start Flush Pump at Flush 2 RPM Setpoint

Wait for Flush 2 Time

Stop Flush Pump

Close Inlet 2

Wait for Flush 2 Hold time.

Proceed to next flush.

Else Proceed to Flush 3

If Flush 3 = Inlet 3 then

Open Inlet 3 valve

Start Flush Pump at Flush 3 RPM Setpoint

Wait for Flush 3 Time

Stop Flush Pump

Close Inlet 3

Wait for Flush 3 Hold time.

Proceed to next flush.

Else proceed to Flush 4



If Flush 4 = Inlet 1 then

Open Inlet 1 valve

Start Flush Pump at Flush 4 RPM Setpoint

Wait for Flush 4 Time

Stop Flush Pump

Close Inlet 1

Wait for Flush 4 Hold time

Proceed to next flush

Else Proceed to Flush 5

If Flush 5 = Inlet 2 then

Open Inlet 2 valve

Start Flush Pump at Flush 5 RPM Setpoint

Wait for Flush 5 Time

Stop Flush Pump

Close Inlet 2

Wait for Flush 5 Hold time

Set the Filter status to ready for filtering

End Flush

Wait for the assigned feed SUSV weight to be above minimum weight

If Feed SUSV pH is enabled, then

Set Feed SUSV pH EM Command to pH control

Enable Feed SUSV pH High and Low alarm

If Feed SUSV Cond is enabled, then

Set Feed SUSV Cond EM Command to Cond control

Enable Feed SUSV Cond High and Low alarm

Wait for the Feed SUSV WT to be above Normal weight limit

Enable Feed SUSV Weight High and Low Alarm

If pH or Cond is enabled, then

Wait for pH or Cond in range .

2.5.3.3.2 Feed command sequence

Filter Feed:

Set active filter valve path to Buffer Pushout

If switchover is not due to Differential pressure high high alarm and not initial filter flush, then

Set active filter valve path to product pushout.

Reset and Start Hold up Volume totalizer.

Start Flush Pump with a Product Flush speed Setpoint.

Open Product pushout Buffer Inlet

If Recovery Switch type is Concentration, then

Wait for the Product Outlet UV to be less than Collection UV Setpoint for 30 seconds or Max Volume reached.

Else if Recovery Switch type is Volume, then

Wait for Hold up Volume totalizer volume is greater than Hold Up Volume Setpoint.

Stop Flush Pump

Close Product pushout Buffer Inlet

Start Feed Pump at Normal speed setpoint.

If Recovery Switch type is Concentration, then

Wait for Waste Outlet UV to be greater than Collection UV Setpoint for 30 secs or Max Volume Reached or Product Pushout completed.

Else If Recovery Switch type is Volume, then

Wait for Hold up Volume totalizer volume is greater than Hold Up Volume Setpoint or Product Pushout completed.

Set active filter valve path to Filter Feed

Enable Feed Pump Speed Control:

If Feed Vessel WT is less than Slow Speed Weight Limit and greater than pause weight limit or Collection SUSV WT is greater than Coll High Weight Limit, then

Set Feed Pump at Slow speed setpoint.

If Feed Vessel WT is greater than Slow Speed Weight Limit and less than High Speed Weight limit, then

If Control Type is Discrete, then

Set Feed Pump speed to Normal speed setpoint.

If Control Type is proportional, then

Set Feed Pump to Feed SUSV Weight Control Setpoint

Set the Feed Pump Speed Output High Limit to a configurable high pump speed limit.

If Feed Vessel WT is greater than Fast Speed Weight limit, then

Set Feed Pump at Fast speed setpoint.

If Feed Vessel WT is less than Pause Weight Limit or Feed SUSV pH or Cond is enabled and Feed SUSV pH or Cond is out of range or Collection SUSV WT is greater than Coll High High Weight Limit, then

Stop Feed Pump

Enable Filter Switchover:

If active filter total flow volume greater than Switchover Volume 1 setpoint or Differential pressure high alarm is active or operator selected switchover, then

Enable clean Filter Flush Sequence

If active filter totalized volume throughput is greater than Switchover Volume 2 setpoint or operator selected switchover or Differential pressure high high alarm is active, then

Disable Feed Pump Speed Control

Set the active Filter status to Dirty Filter

Check if filter bank 1 status is ready for filtering.

Set filter 1 status to active filter.

Else if filter bank 2 status is ready to filter.

Set filter 2 status to active filter.

Else alarm if none of the filter is available.

Return to Filter Feed

Enable Divert Valve Control Feed:

If Feed Vessel weight is greater than High Weight Limit, then

open process break valve

close outlet valve

Else

open outlet valve

close process break valve

2.5.3.3.3 Shutdown command sequence

If Feed SUSV WT is greater than Slow Speed Weight Limit and less than High Speed Weight limit, then

If Control Type is Discrete, then

Set skid flow rate to Normal speed setpoint

If Control Type is Proportional, then

Set Skid flow rate to Feed SUSV Weight Control Setpoint

If Feed SUSV WT is greater than Fast Speed Weight limit, then

Set skid flow rate to Fast speed setpoint

If Feed SUSV WT is less than Pause Weight Limit or Feed SUSV pH or Cond is enabled and Feed SUSV pH or Cond is out of range or Collection SUSV WT is greater than Coll High High Weight Limit, then

Pause skid recipe

Wait for the Feed vessel weight to be below empty weight limit

Disable Feed Pump Speed Control

Disable Flush Sequence

Stop Feed Pump

2.5.3.3.4 Abort command sequence

Disable Feed Pump Speed Control

Disable Flush Sequence

If Feed Vessel pH is enabled, then

Set Feed Vessel pH EM Command to Shutdown

Disable Feed Vessel pH High and Low alarm

If Feed Vessel Cond is enabled, then

Set Feed Vessel Cond EM Command to Shutdown

Disable Feed Vessel Cond High and Low alarm

Disable Feed Vessel Weight High and Low Alarm

Stop Feed Pump

Stop Flush Pump

Close all valves

2.5.3.3.5 Hold command sequence

Disable Feed Pump Speed Control

Disable Flush Sequence

Stop Feed Pump

Stop Flush Pump

Close all valves

2.5.3.3.6 Failure Monitor

Filter is not available

2.5.3.4 Alarms

List of unit alarms:

PT01 High High Alarm

PT01 High Alarm

Filter Feed Differential Pressure (P01-P04) High High Alarm

Filter Feed Differential Pressure (P01-P04) High Alarm

Filter Flush Differential Pressure (P05-P04) High Alarm

PT05 High High Alarm

PT05 High Alarm

Collection Outlet UV Low warning alarm

Waste Outlet UV High Warning Alarm

- Alarm's rationalization will be performed to enable and disable process alarms during the active process step.
 - All high-pressure alarms will always be enabled
 - Enable UV collection low alarm in Feed sequence
- SUSV alarms will be enabled and disabled during the active skid process.
 - This applies to all SUSV vessels

- Disable Module bad alarms when the skid or SUSV is disconnected.

2.5.3.5 Interlocks

Interlock Condition	Device	Safe State
N/A	N/A	N/A

2.5.4 Viral Inactivation

2.5.4.1 Overview

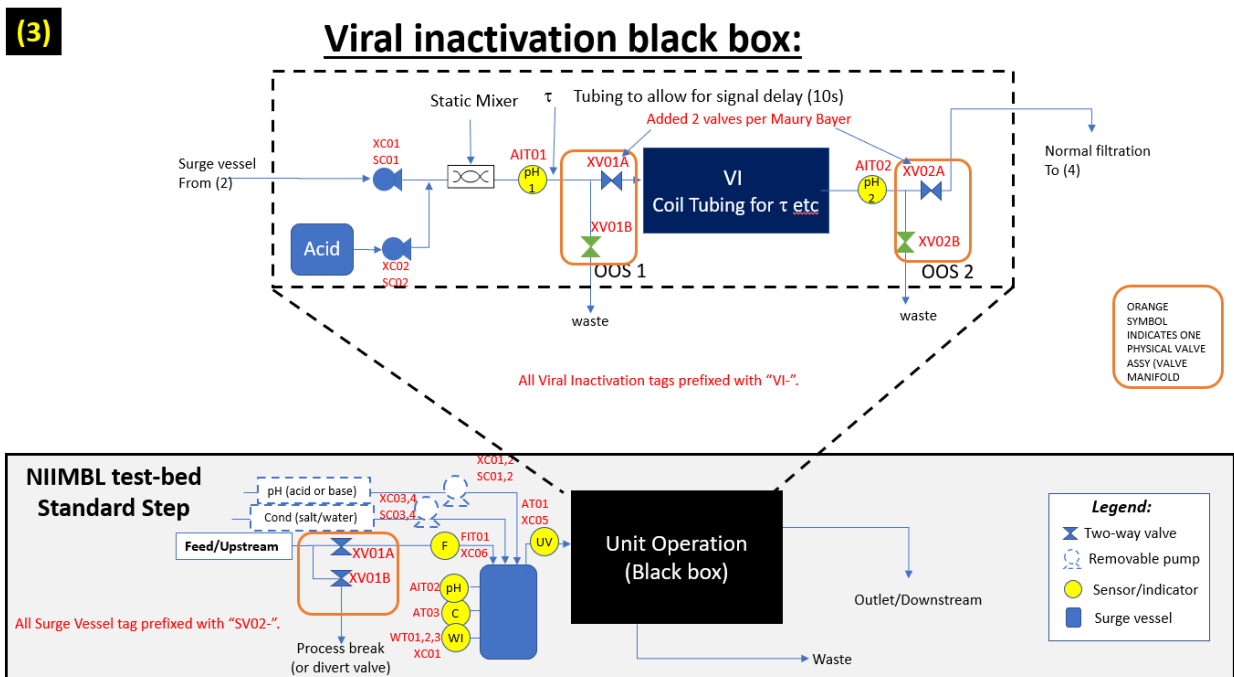

Figure – P&ID Diagram

Devices	Collection	VI Inlet Drain	VI Outlet Drain
XV01A	O	C	O
XV01B	C	O	C
XV02A	O	C	C
XV02B	C	C	O

Table – Valve Path

2.5.4.2 Phase

The Viral Inactivation Control Phase will initialize, start, Feed and Shutdown the equipment module to facilitate procedural operations based on recipe parameter values. The Phase is also responsible for monitoring end of the running batch based on the operator acknowledgement or auto shutdown detection if the upstream skid batch goes to an idle state. Feed SUSV and collection SUSV are assigned to the unit operation using the recipe formula. Phase will update the unit state to Start up, Feed, Pause, Shutdown (Draw down is complete), Abort, Idle.

2.5.4.3 Equipment Module

The EM regulates the standard feed process rate on the skid using flow or speed setpoint by monitoring the feed and collection SUSV weight assigned to the skid. The permitted feed process rate setpoints include Pause, Slow, Fast, and Normal. The EM will pause the skid if the feed SUSV pH is OOS (for 10S). The skid master EM will transition from feed to an end setpoint by the phase upon operator acknowledgement or auto shutdown detection if the upstream skid batch goes to an idle state.

The equipment module will run following command sequences.

- Startup
- Feed/Process
- Shutdown
- Abort
- Hold

2.5.4.3.1 Startup command sequence

Operator Acknowledge pH probe 1 (AIT01) is calibrated

Operator Acknowledge pH probe 2 (AIT02) is calibrated

Enable Inlet pH High and High High alarms

Disable Feed Tank Weight alarms

If Feed SUSV pH is enabled, then

 Disable Feed SUSV pH High and Low alarm

If Feed SUSV Cond is enabled, then

 Disable Feed SUSV Cond High and Low alarm

Enable Feed SUSV Weight Control

Wait for the assigned feed SUSV weight to be above minimum weight

If Feed SUSV pH is enabled, then

 Set Feed SUSV pH Control parameters

Set Feed SUSV pH EM Command to pH control

If Feed SUSV Cond is enabled, then

Set Feed SUSV Conductivity Control parameters

Set Feed SUSV Cond EM Command to Cond control

Wait for the Feed SUSV WT to be above Normal weight limit

Enable Feed SUSV Weight High and Low Alarm

If Feed SUSV pH is enabled, then

Enable Feed SUSV pH High and Low alarm

If Feed SUSV Cond is enabled, then

Enable Feed SUSV Cond High and Low alarm

If pH or Cond is enabled, then

Wait for pH or Cond in range

2.5.4.3.2 Feed command sequence

VI Feed:

Set VI valve path to VI Inlet Drain

Set Feed Pump speed to Normal speed setpoint

Set Acid Pump speed output in proportion to Feed pump Normal speed

Enable inline pH Control with pH Titration setpoint

Note: pH1 will initially be OOS

Wait until pH1 is within High and Low Tolerance Setpoint for a configurable stabilization time

Set VI valve path to Collection

Monitor pH 1 and pH 2

Enable Feed Pump Speed Control:

If Feed Vessel WT is less than Slow Speed Weight Limit and greater than pause weight limit or Collection SUSV WT is greater than Coll High Weight Limit, then

Set Feed Pump at Slow speed setpoint

Set Acid Pump speed output in proportion to Feed pump slow speed

Enable inline pH Control to pH Titration setpoint

If Feed Vessel WT is greater than Slow Speed Weight Limit and less than High Speed Weight limit, then

If Control Type is Discrete, then

Set Feed Pump speed to Normal speed setpoint

Set Acid Pump speed output in proportion to Feed pump Normal speed

Enable inline pH Control with pH Titration setpoint

If Control Type is proportional, then

Set Feed Pump to Feed SUSV Weight Control Setpoint

If Feed Vessel WT is greater than Fast Speed Weight limit, then

Set Feed Pump at Fast speed setpoint

Set Acid Pump speed output in proportion to Feed pump Fast speed

Enable inline pH Control with pH Titration setpoint

If Feed Vessel WT is less than Pause Weight Limit or Feed SUSV pH or Cond is enabled and Feed SUSV pH or Cond is out of range or Collection SUSV WT is greater than Coll High High Weight Limit, then

Stop Feed Pump

Note: Acid pump flowrate should change proportionally with feed pump flow rate for discrete control

During feed if feed pump is running then

Monitor pH1 and pH2

Else

disable pH1 and pH2 monitoring.

VI Inlet pH out of specification:

If pH 1 is outside High and Low Tolerance Setpoint for a configurable stabilization time, then

Set VI valve path to VI Inlet drain.

Wait until pH1 is within High and Low Tolerance Setpoint for a configurable stabilization time then

Set VI valve path to Collection.

Monitor pH 1 and pH 2

VI Outlet pH out of specification:

If pH 2 is outside High and Low Tolerance Setpoint for a configurable stabilization time, then

Set VI valve path to VI Outlet drain.

Wait until pH2 is within High and Low Tolerance Setpoint for a configurable stabilization time then

Set VI valve path to Collection.

Monitor pH 1 and pH 2

VI extended pause specification:

Upon returning from pause during feed

If feed pump is paused for more than configurable delay time, then

Set VI valve path to VI Outlet drain.

Wait for a configurable residence time

Wait until pH2 is within High and Low Tolerance Setpoint for a configurable stabilization time then

Set VI valve path to Collection.

Monitor pH 1 and pH 2

Else proceed to feed

2.5.4.3.3 Shutdown command sequence

If Feed SUSV WT is greater than Slow Speed Weight Limit and less than High Speed Weight limit, then

If Control Type is Discrete, then

Set skid flow rate to Normal speed setpoint

If Control Type is Proportional, then

Set Skid flow rate to Feed SUSV Weight Control Setpoint

If Feed SUSV WT is greater than Fast Speed Weight limit, then

Set skid flow rate to Fast speed setpoint

If Feed SUSV WT is less than Pause Weight Limit or Feed SUSV pH or Cond is enabled and Feed SUSV pH or Cond is out of range or Collection SUSV WT is greater than Coll High High Weight Limit, then

Pause skid recipe

Wait for the Feed vessel weight to be below empty weight limit

Disable inline pH control

Stop Acid pump

Stop Feed Pump

Close all Valves

2.5.4.3.4 Abort command sequence

Disable Feed Tank Weight alarms

If Feed Vessel pH is enabled, then

Disable Feed Vessel pH High and Low alarm

If Feed Vessel Cond is enabled, then

Disable Feed Vessel Cond High and Low alarm

Disable Inlet pH alarms

Disable inline pH control

Disable Feed Pump Speed Control

Stop Acid pump

Stop Feed Pump

Close all Valves

If Feed Vessel pH is enabled, then

Set Feed Vessel pH EM Command to Shutdown

If Feed Vessel Cond is enabled, then

Set Feed Vessel Cond EM Command to Shutdown

2.5.4.3.5 Hold command sequence

Disable Feed Pump Speed Control

Stop Feed Pump

Stop Acid Pump

Close all valves

2.5.4.3.6 Failure Monitor

pH1 device failure

pH2 device failure

2.5.4.4 Advanced Control

Feed forward on pH control – anticipate pH gradient from chromatography elution.

2.5.4.5 Alarms

Maximum time when VI path is set VI Inlet Drain or VI Outlet drain when feed pump active.

pH ranges high and low sides for acid measurements.

2.5.4.6 Interlocks

Interlock Condition	Device	Safe State
N/A	N/A	N/A



2.6 Purification/Polishing Chromatography

2.6.1 Single Use Chromatography:

Refer to section 1.5.1.

2.6.2 Viral Filtration:

Refer to section 1.5.2.

2.7 Filtration (Post Viral / Formulation)

2.7.1 ILDF/UFD

2.7.1.1 Overview

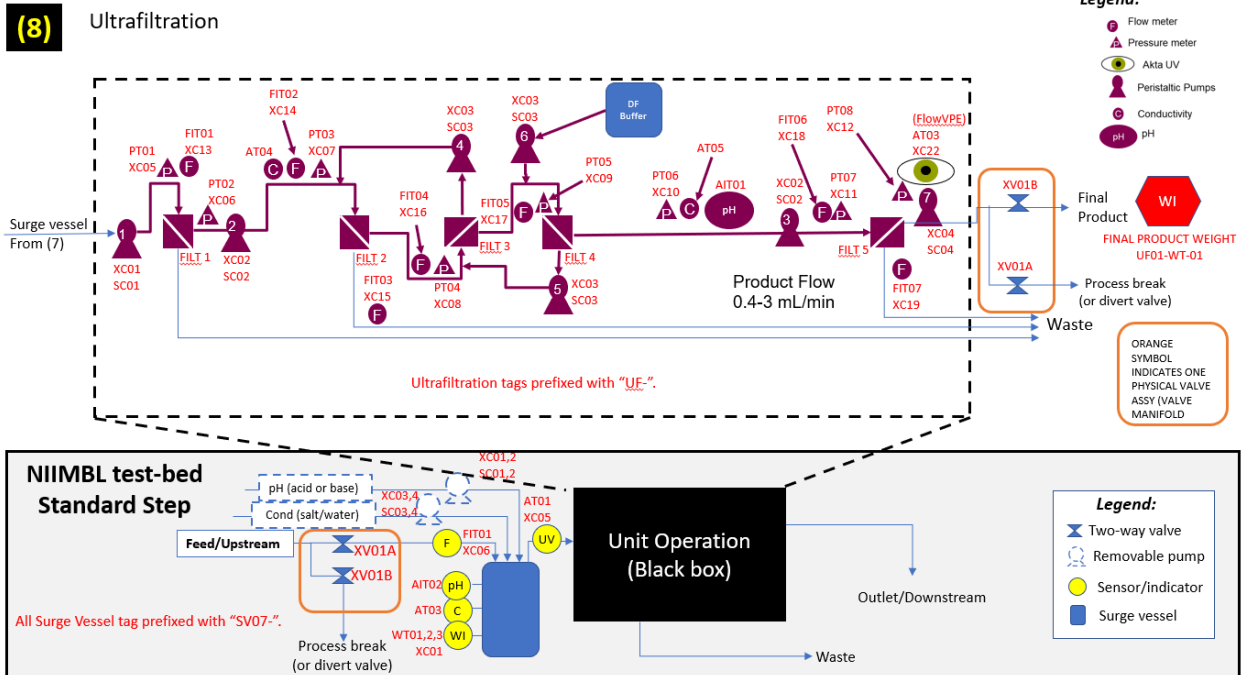

2.7.1.2 Phase

The ILDF Skid Control Phase will initialize, start, Feed and Shutdown the equipment module to facilitate procedural operations based on recipe parameter values. The Phase is also responsible for monitoring end of the running batch based on the operator acknowledgement or auto shutdown detection if the upstream skid batch goes to an idle state

Feed SUSV and collection SUSV are assigned to the unit operation using the recipe formula.

Phase will update the unit state to Start up, Feed, Pause, Shutdown (Draw down is complete), Abort, Idle.

2.7.1.3 Equipment Module

The EM regulates the standard feed process rate on the skid using flow or speed setpoint by monitoring the feed and collection SUSV weight assigned to the skid. The permitted feed process rate setpoints include Pause, Slow, Fast, and Normal. The EM will pause the skid if the feed SUSV pH is OOS (for 10S).

The skid master EM will transition from feed to an end setpoint by the phase upon operator acknowledgement or auto shutdown detection if the upstream skid batch goes to an idle state.

The equipment module will run following command sequences.

- Hold
- Startup
- Feed/Process
- Shutdown
- Abort

2.7.1.3.1 Startup command sequence

Prompt Operator to confirm if filter installed and flushed.

Prompt Operator ready to tare pressure PT01-PT-08.

Prompt Operator ready to tare Flow FIT01-FIT07.

Prompt Operator ready to tare assigned Feed SUSV UV AT03.

Wait for the assigned feed SUSV weight to be above minimum weight

If Feed SUSV pH is enabled, then

Set Feed SUSV pH EM Command to pH control

Enable Feed SUSV pH High and Low alarm

If Feed SUSV Cond is enabled, then

Set Feed SUSV Cond EM Command to Cond control

Enable Feed SUSV Cond High and Low alarm

Wait for the Feed SUSV WT to be above low weight limit

Enable Feed SUSV Weight High and Low Alarm

If pH or Cond is enabled, then

Wait for pH or Cond in range

2.7.1.3.2 Feed command sequence

Enable High and High alarms in alarm section.

Enable Feed Pump Speed Control:

If Feed SUSV WT is less than Slow Speed Weight Limit and greater than pause weight limit or Collection SUSV WT is greater than Coll High Weight Limit, then

Set Feed Pump speed to Slow speed setpoint

Set ILDF Pump to $ILDF_Multiplier * Slow\ speed\ setpoint$

Set Buff Pump to $Buff_Multiplier * Slow\ speed\ setpoint$

Set Conc Pump Speed to Minimum Conc speed Setpoint

Set Outlet Conc Control to Outlet Conc Setpoint

Set Outlet Conc Control Output Limit to Minimum Conc Output Setpoint

Set Outlet Conc Control Output Limit to Maximum Conc Output Setpoint

Enable Low Low and Low alarms in alarm section.

If Feed SUSV WT is greater than Slow Speed Weight Limit and less than High Speed Weight limit, then

If Control Type is Discrete, then

Set Feed Pump speed to Normal speed setpoint

If Control Type is proportional, then

Set Feed Pump to Feed SUSV Weight Control Setpoint

Set ILDF Pump to $ILDF_Multiplier * Normal\ speed\ setpoint$

Set Buff Pump to $Buff_Multiplier * Normal\ speed\ setpoint$

Set Outlet Conc Control to Outlet Conc Control Setpoint

Set Outlet Conc Control Output Limit to Minimum Conc Output Setpoint

Set Outlet Conc Control Output Limit to Maximum Conc Output Setpoint

If Feed SUSV WT is greater than Fast Speed Weight limit, then

Set Feed Pump to Fast speed setpoint

Set ILDF Pump to $ILDF_Multiplier * Fast\ speed\ setpoint$

Set Buff Pump to $Buff_Multiplier * Fast\ speed\ setpoint$

Set Outlet Conc Control to Outlet Conc Control Setpoint

Set Outlet Conc Control Output Limit to Minimum Conc Output Setpoint

Set Outlet Conc Control Output Limit to Maximum Conc Output Setpoint

If Feed SUSV WT is less than Pause Weight Limit or Feed SUSV pH or Cond is enabled and Feed SUSV pH or Cond is out of range or Collection SUSV WT is greater than Coll High High Weight Limit, then

Stop Feed Pump

Stop ILDF Pump

Stop Buff Pump

Stop Conc Pump

Enable Feed Vessel Divert Valve Control:

If Feed SUSV weight is greater than High Weight Limit

open process break valve

close outlet valve

Else

open outlet valve

close process break valve

Enable collection Vessel Divert Valve Control:

If Collection SUSV weight is greater than High Weight Limit **or** Outlet UV AT03 is greater than Collection Conc Setpoint, then

open process break valve

close outlet valve

Else

open outlet valve

close process break valve

2.7.1.3.3 Shutdown command sequence

Disable Low and Low Low alarms in alarm section

If Feed SUSV WT is greater than Slow Speed Weight Limit and less than High Speed Weight limit, then

If Control Type is Discrete, then

Set skid flow rate to Normal speed setpoint

If Control Type is Proportional, then

Set Skid flow rate to Feed SUSV Weight Control Setpoint

If Feed SUSV WT is greater than Fast Speed Weight limit, then

Set skid flow rate to Fast speed setpoint

If Feed SUSV WT is less than Pause Weight Limit or Feed SUSV pH or Cond is enabled and Feed SUSV pH or Cond is out of range or Collection SUSV WT is greater than Coll High High Weight Limit, then

Pause skid recipe

Wait for the Feed SUSV weight to be below empty weight limit

Disable Feed Pump Speed Control

Stop Feed Pump

Stop ILDF Pump

Stop Buff Pump

Stop Conc Pump

2.7.1.3.4 Abort command sequence

Disable Feed Pump Speed Control

Disable Feed SUSV Divert Valve Control

Disable Collection SUSV Divert Valve Control

If Feed SUSV pH is enabled, then

Set Feed SUSV pH EM Command to Shutdown

Disable Feed SUSV pH High and Low alarm

If Feed SUSV Cond is enabled, then

Set Feed SUSV Cond EM Command to Shutdown

Disable Feed SUSV Cond High and Low alarm

Disable Feed SUSV Weight High and Low Alarm

Disable all alarms in alarm section

Stop Feed Pump

Stop ILDF Pump

Stop Buff Pump

Stop Conc Pump

Close all valves

2.7.1.3.5 Hold command sequence

Disable Feed Pump Speed Control

Stop Feed Pump

Stop ILDF Pump

Stop Buff Pump

Stop Conc Pump

Close all valves

2.7.1.3.6 Failure Monitor

Skid paused locally

2.7.1.4 Alarms

List of unit alarms:

PT01-PT08 High High Alarm

PT01-PT08 High Alarm

PT01-PT08 Low Alarm

PT01-PT08 Low Low Alarm

FIT01-FIT07 High High Alarm

FIT01-FIT07 High Alarm

FIT01-FIT07 Low Alarm

FIT01-FIT07 Low Low Alarm

AT04-AT05 High High Alarm

AT04-AT05 High Alarm

AT04-AT05 Low Alarm

AT04-AT05 Low Low Alarm

AT03 High High Alarm

AT03 High Alarm

AT03 Low Alarm

AT03 Low Low Alarm

Feed SUSV AIT02 High Alarm

Feed SUSV AIT02 Low Alarm

Feed SUSV AT03 High Alarm

Feed SUSV AT03 Low Alarm

Feed SUSV WT01 High Alarm

Feed SUSV WT01 Low Alarm

- Alarm's rationalization will be performed to enable and disable process alarms during the active process step.
- SUSV alarms will be enabled and disabled during the active skid process.
- Disable Module bad alarms when the skid or SUSV is disconnected.

2.7.1.5 Interlocks

Interlock Condition	Device	Safe State
N/A	N/A	N/A

2.8 Equipment Interfaces

Skid	EQUIPMENT ID	Model	OEM Vendor	OEM Interface
Bioreactor	BR01			OPC UA, Profibus, or ...
Perfusion	PERF01			
Perfusion	PERF02			
Capture Chromatography	CC01			
Capture Chromatography	CC02			
Viral Inactivation	VI01		NA – Native PAS	NA – Native PAS
Depth Filtration	DF01		NA – Native PAS	NA – Native PAS
Polishing Chromatography	CS01			
Viral Filtration	VF01		NA – Native PAS	NA – Native PAS
ILDF/UFDF	UF01		NA – Native PAS	NA – Native PAS
SUSV	SV01-07		NA – Native PAS	NA – Native PAS